

27. Immobilizer System

A: WIRING DIAGRAM

1. ENGINE TYPE FA (WITHOUT PUSH BUTTON START)

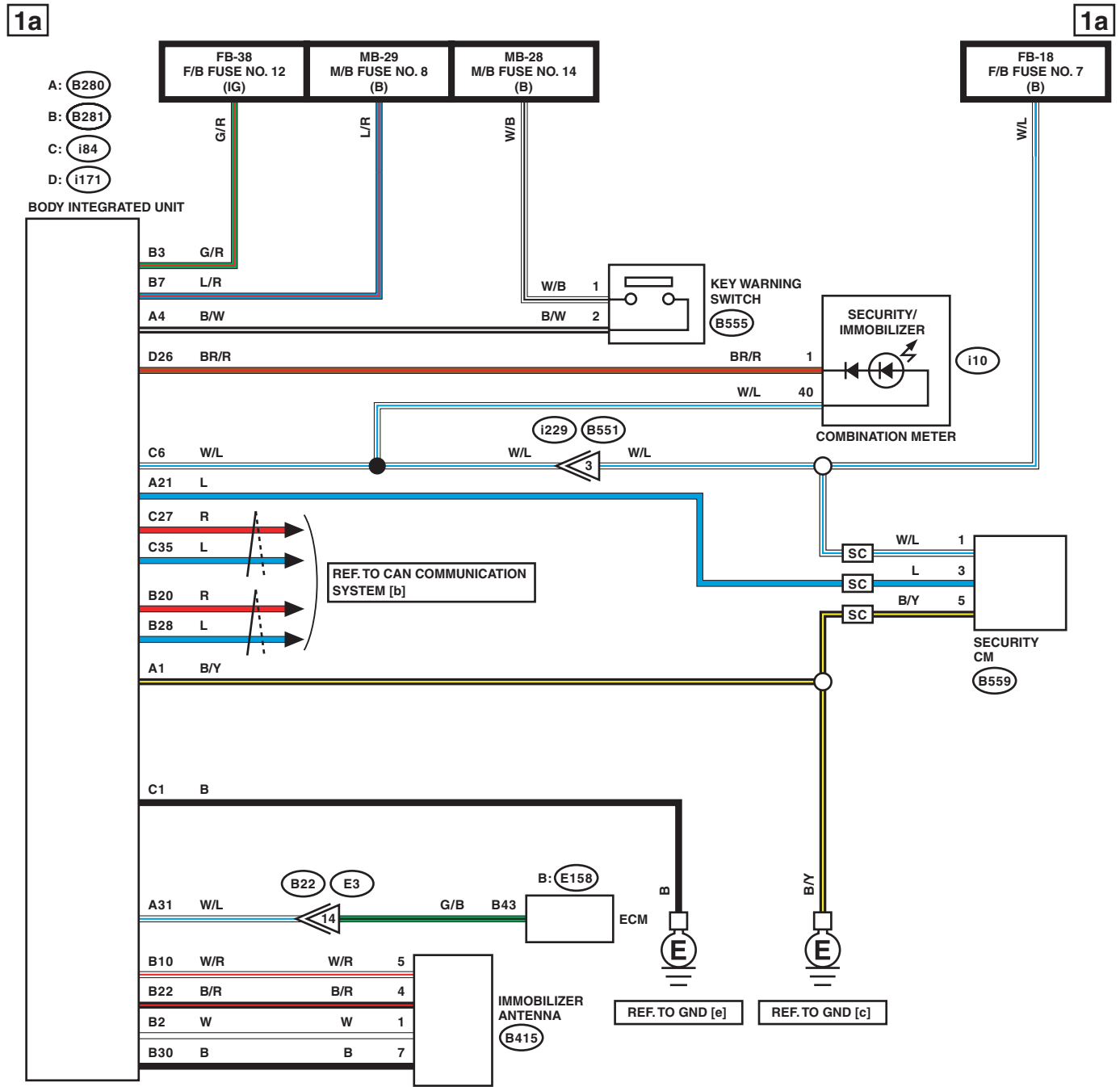

SC : WITH SECURITY CM

Immobilizer System

WIRING SYSTEM

1b

1b

LIST OF CONNECTORS

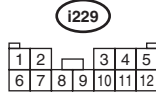
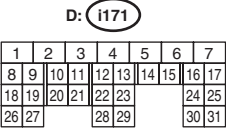
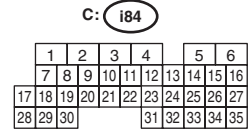
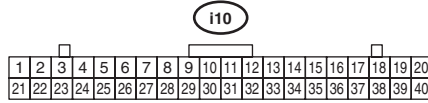
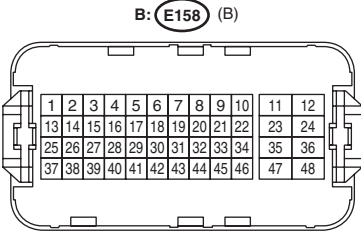
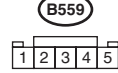
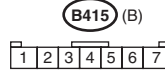
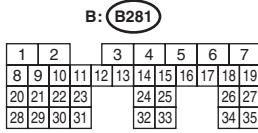
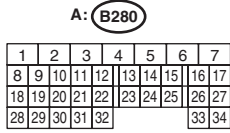
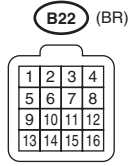

Immobilizer System

2. ENGINE TYPE FA (WITH PUSH BUTTON START)

2a

2a

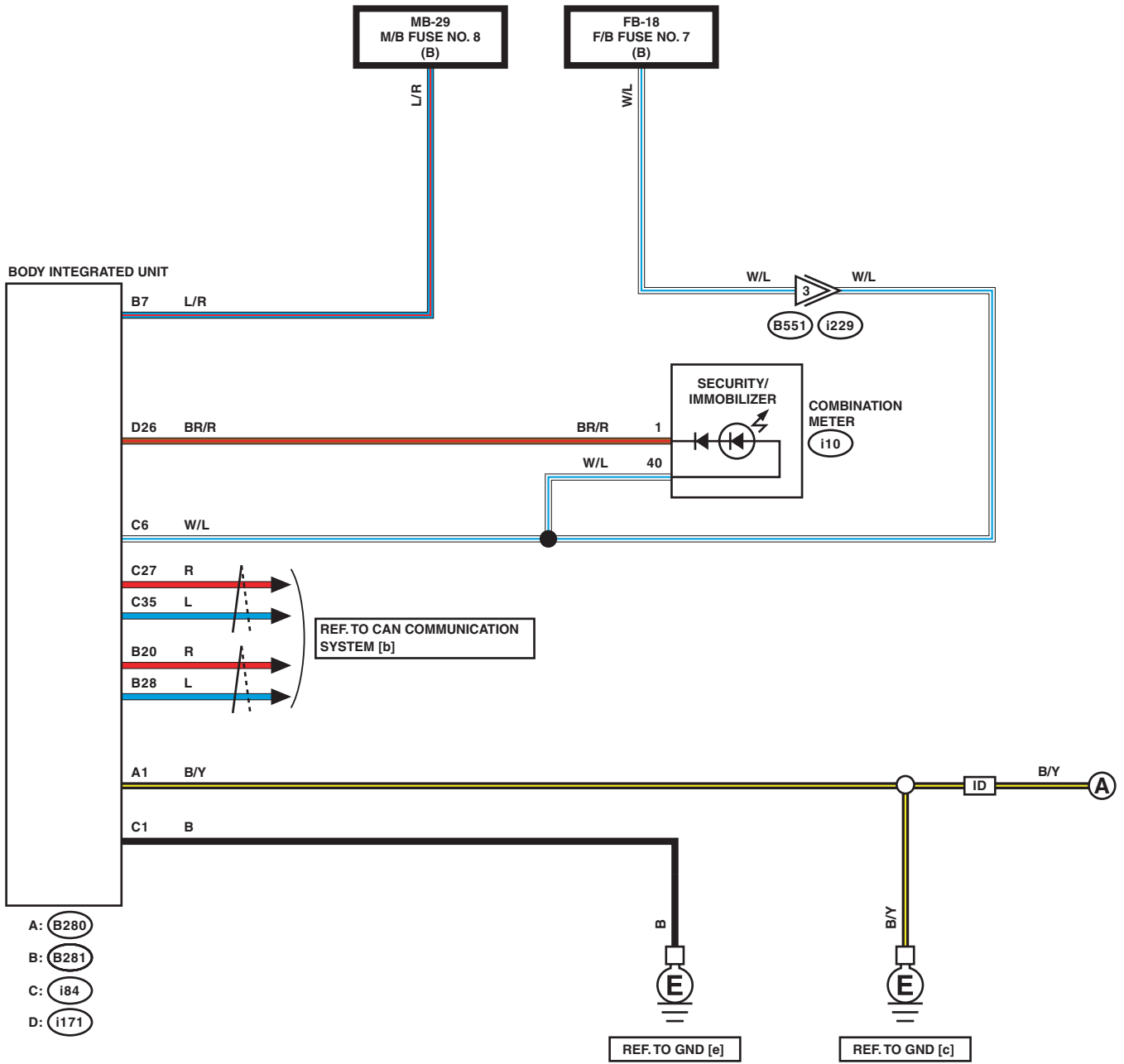

ID : WITH ID CODE BOX

Immobilizer System

WIRING SYSTEM

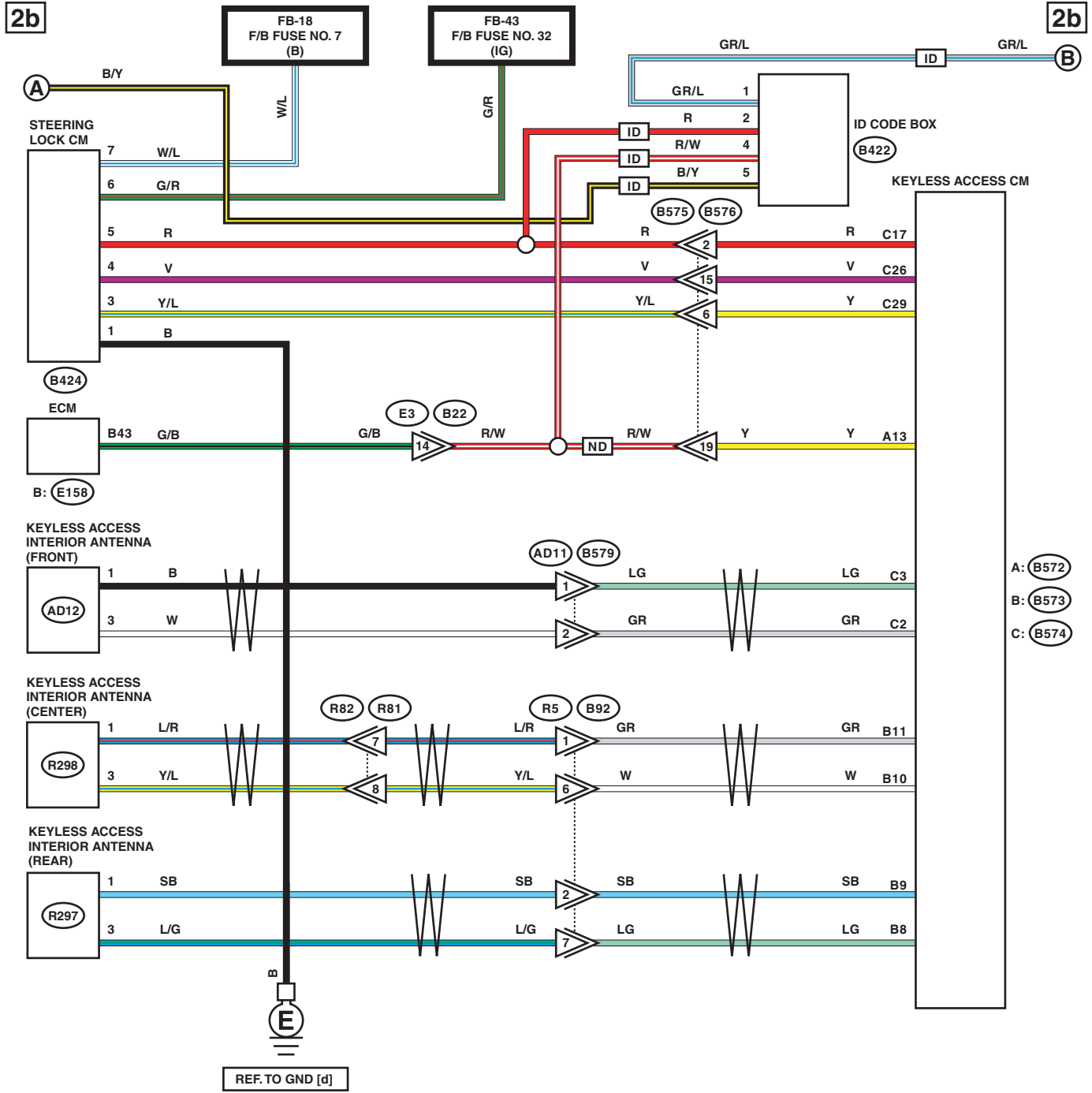

ND : WITHOUT ID CODE BOX
ID : WITH ID CODE BOX

WI-44461

Immobilizer System

WIRING SYSTEM

2c

2c

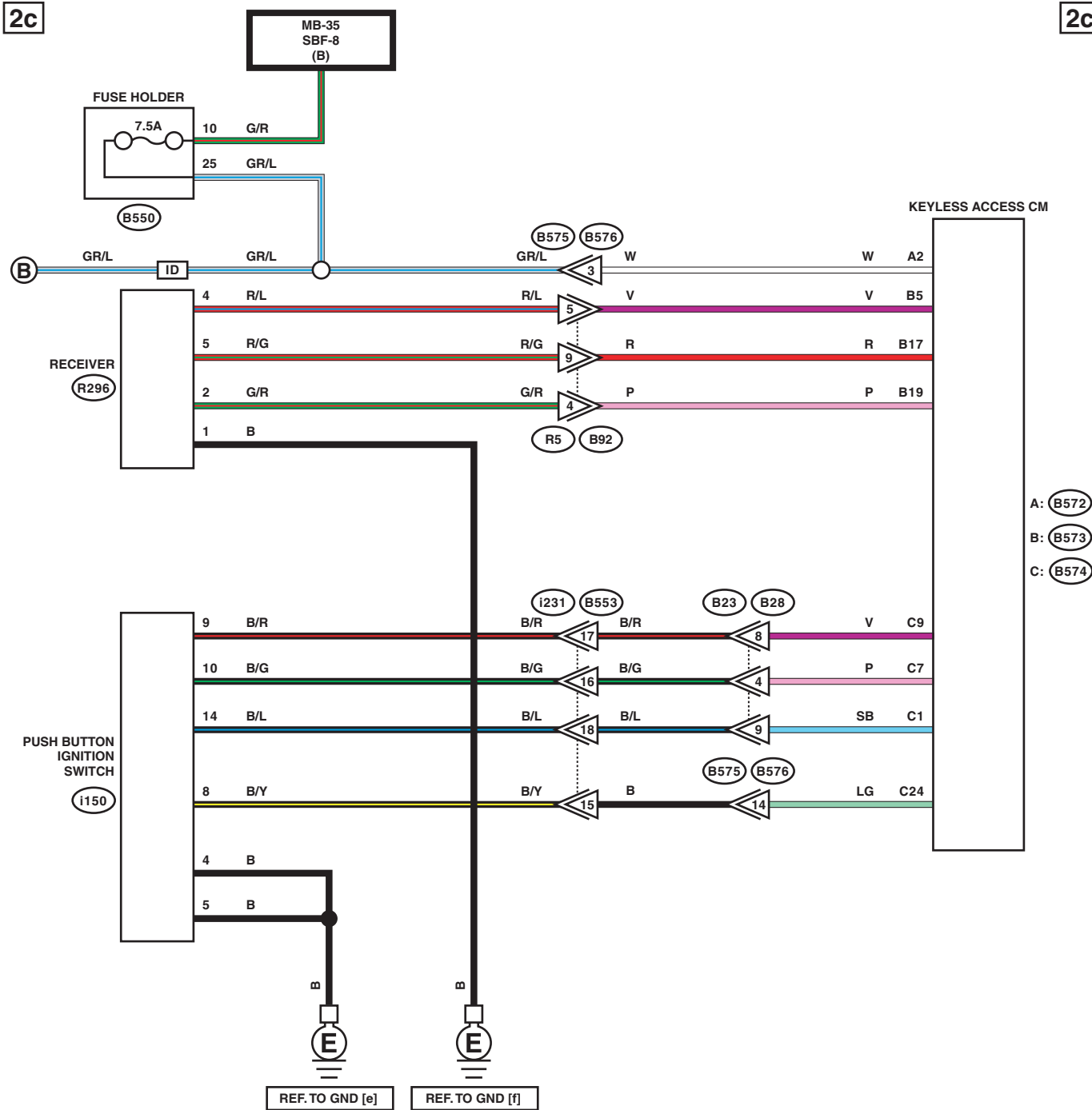

ID : WITH ID CODE BOX

WI-44462

Immobilizer System

WIRING SYSTEM

2d

2d

LIST OF CONNECTORS

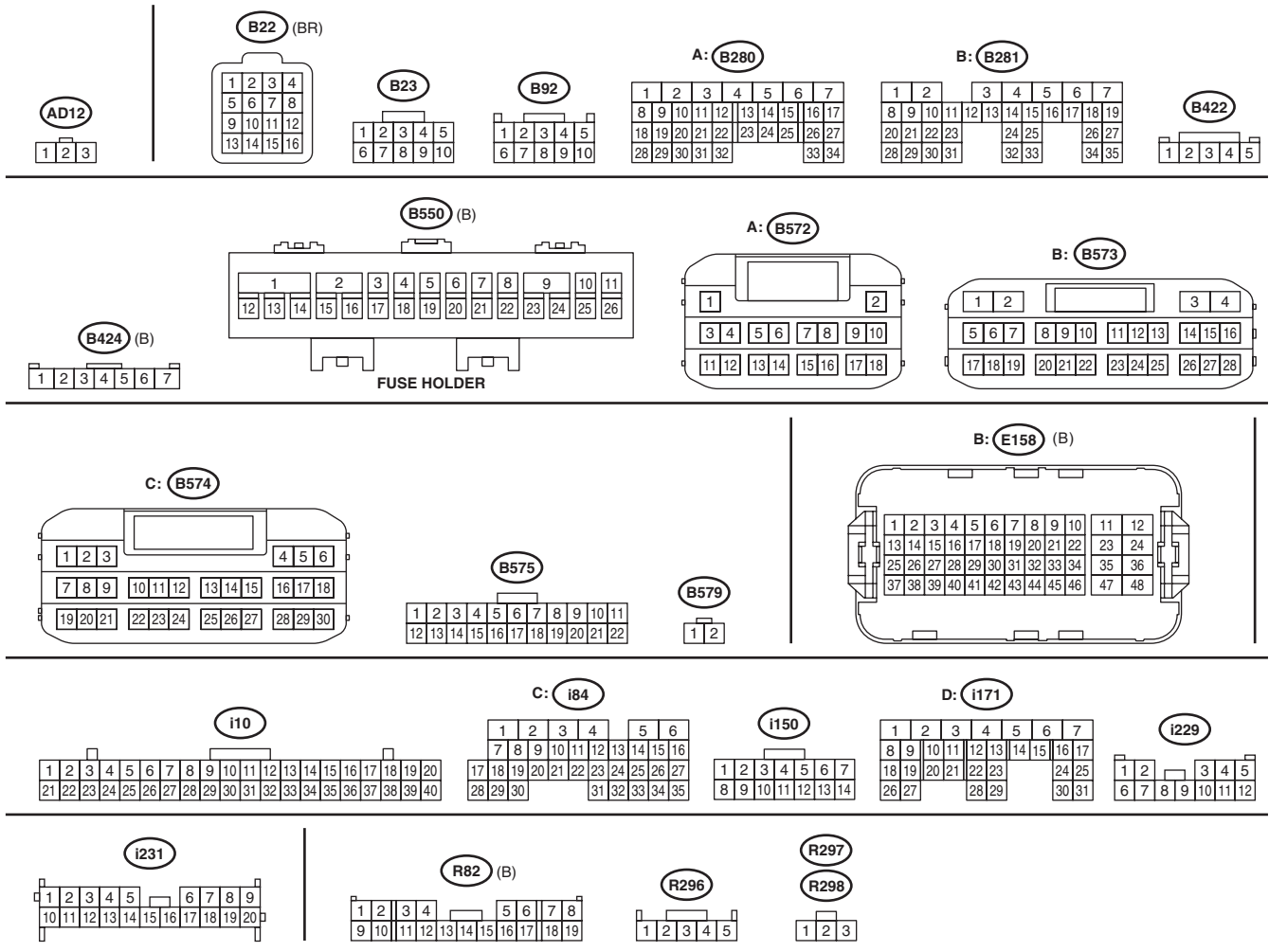

WI-44463

Immobilizer System

WIRING SYSTEM

3b

3b

LIST OF CONNECTORS

B: B135

B: B281

1	2		3	4	5	6	7				
8	9	10	11	12	13	14	15	16	17	18	19
20	21	22	23		24	25		26	27		
28	29	30	31		32	33		34	35		

A: B280

1	2	3	4	5	6	7			
8	9	10	11	12	13	14	15	16	17
18	19	20	21	22	23	24	25	26	27
28	29	30	31	32				33	34

B415 (B)

1	2	3	4	5	6	7
---	---	---	---	---	---	---

B555

1	2
---	---

B559

1	2	3	4	5
---	---	---	---	---

i10

1	2	3	4	5	6	7	8	9	10	11	12	13	14	15	16	17	18	19	20	
21	22	23	24	25	26	27	28	29	30	31	32	33	34	35	36	37	38	39	40	

C: i84

1	2	3	4	5	6					
7	8	9	10	11	12	13	14	15	16	
17	18	19	20	21	22	23	24	25	26	27
28	29	30		31	32	33	34	35		

D: i171

1	2	3	4	5	6	7			
8	9	10	11	12	13	14	15	16	17
18	19	20	21	22	23			24	25
26	27			28	29			30	31

i229

1	2		3	4	5	
6	7	8	9	10	11	12

WI-44465

Immobilizer System

WIRING SYSTEM

4. ENGINE TYPE EJ (WITH PUSH BUTTON START)

4a

4a

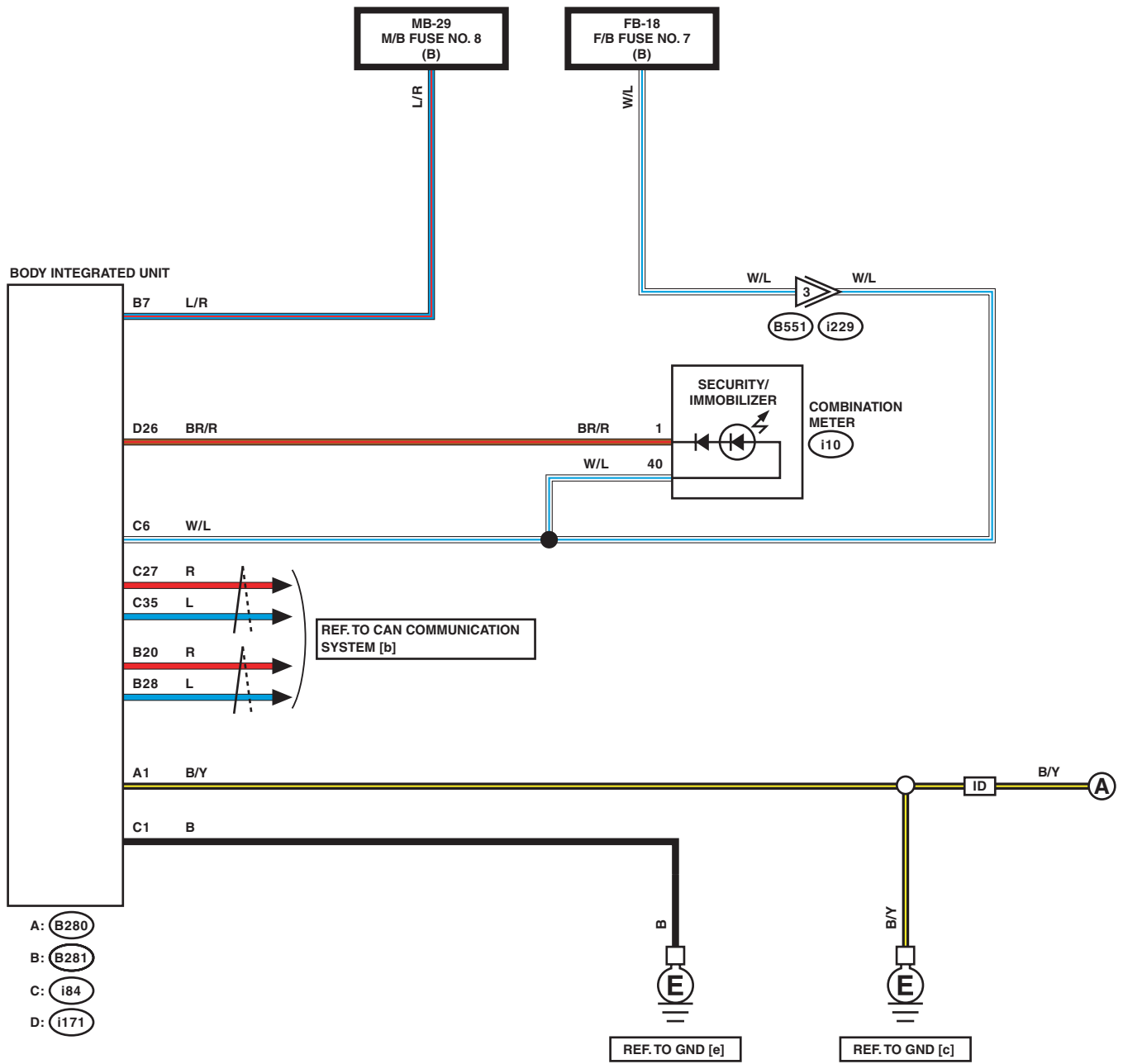

ID : WITH ID CODE BOX

WI-44466

Immobilizer System

WIRING SYSTEM

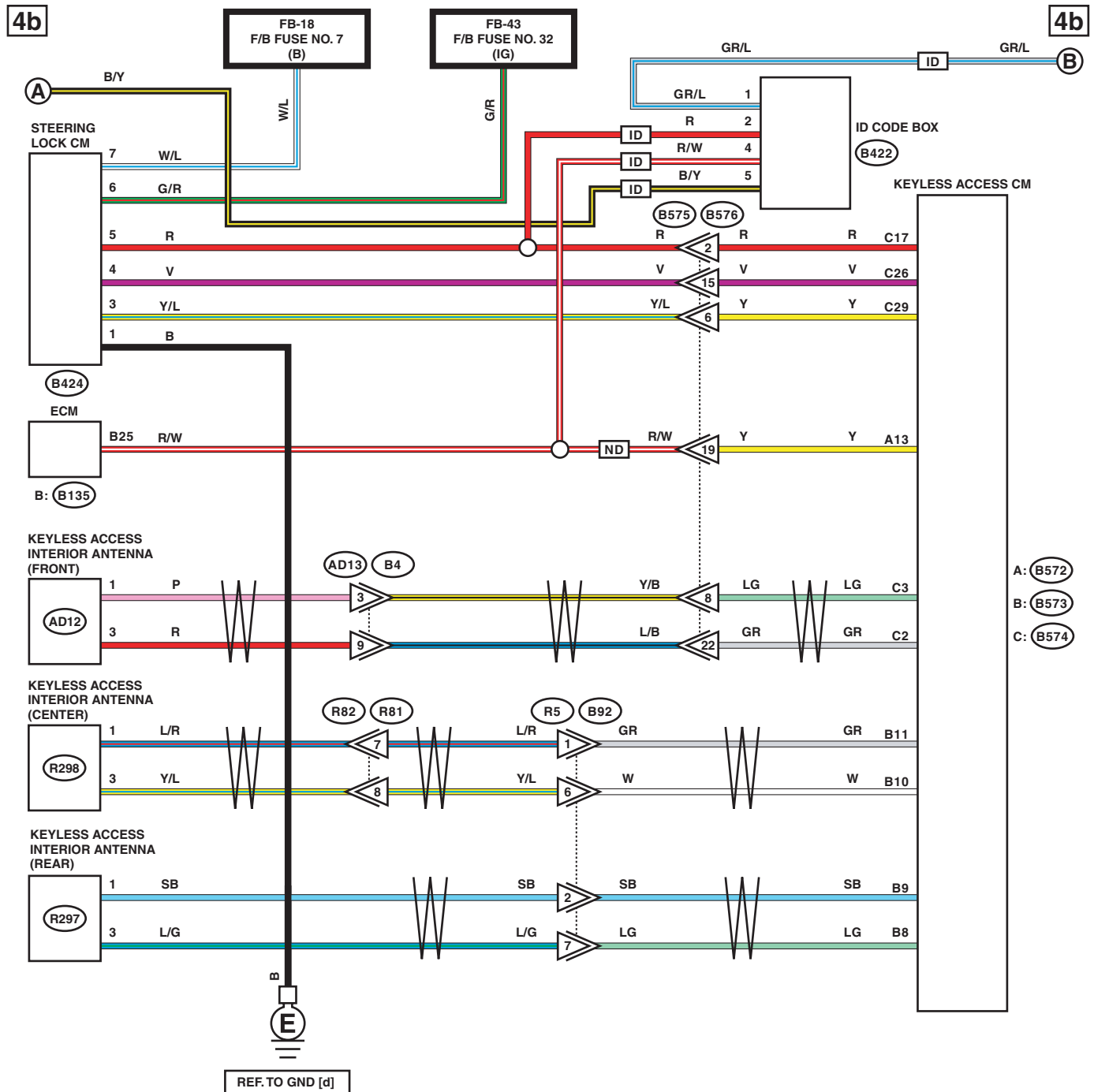

ND : WITHOUT ID CODE BOX
 ID : WITH ID CODE BOX

WI-44467

Immobilizer System

WIRING SYSTEM

4c

4c

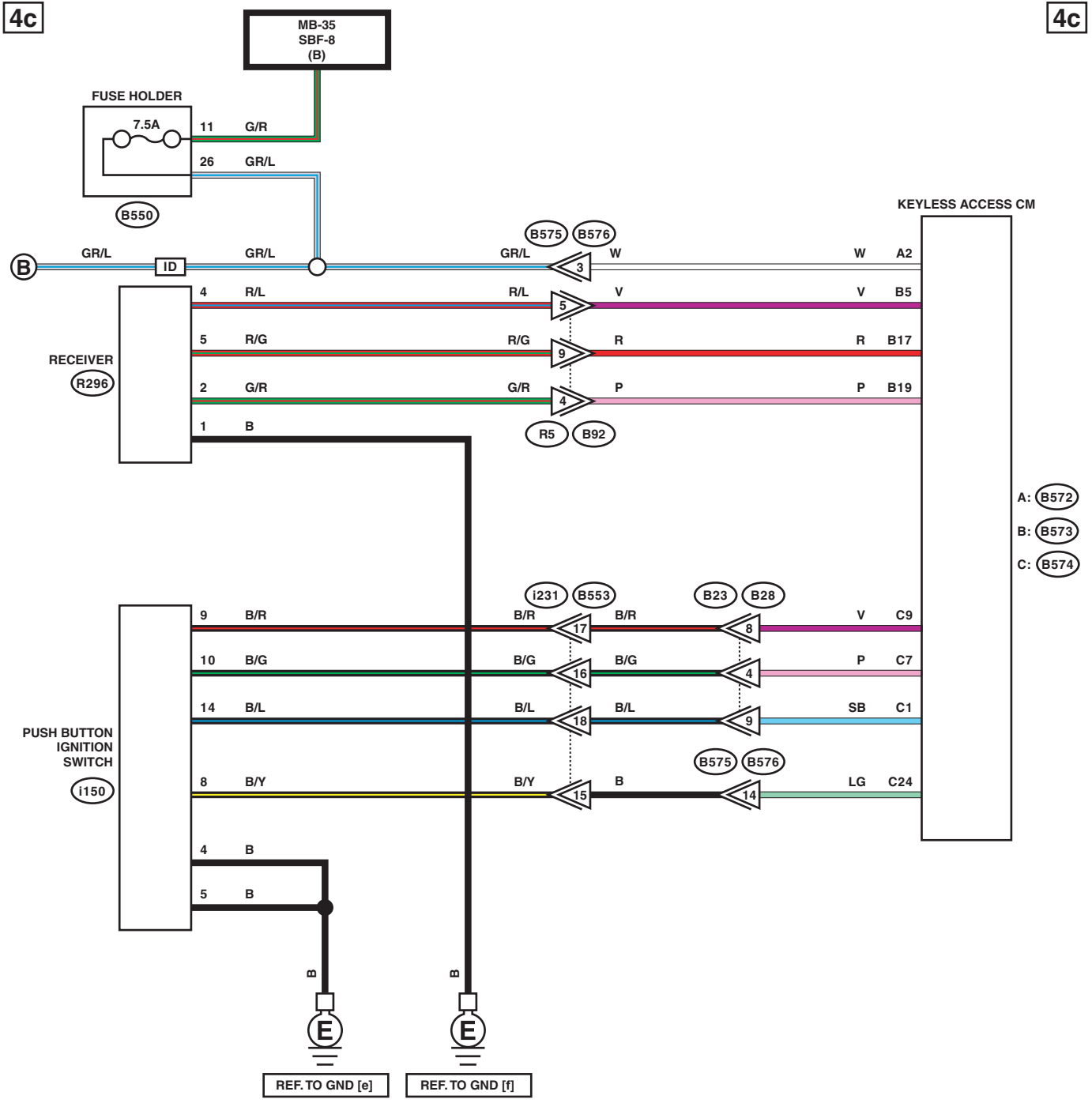

WI-44468

Immobilizer System

WIRING SYSTEM

4d

4d

LIST OF CONNECTORS

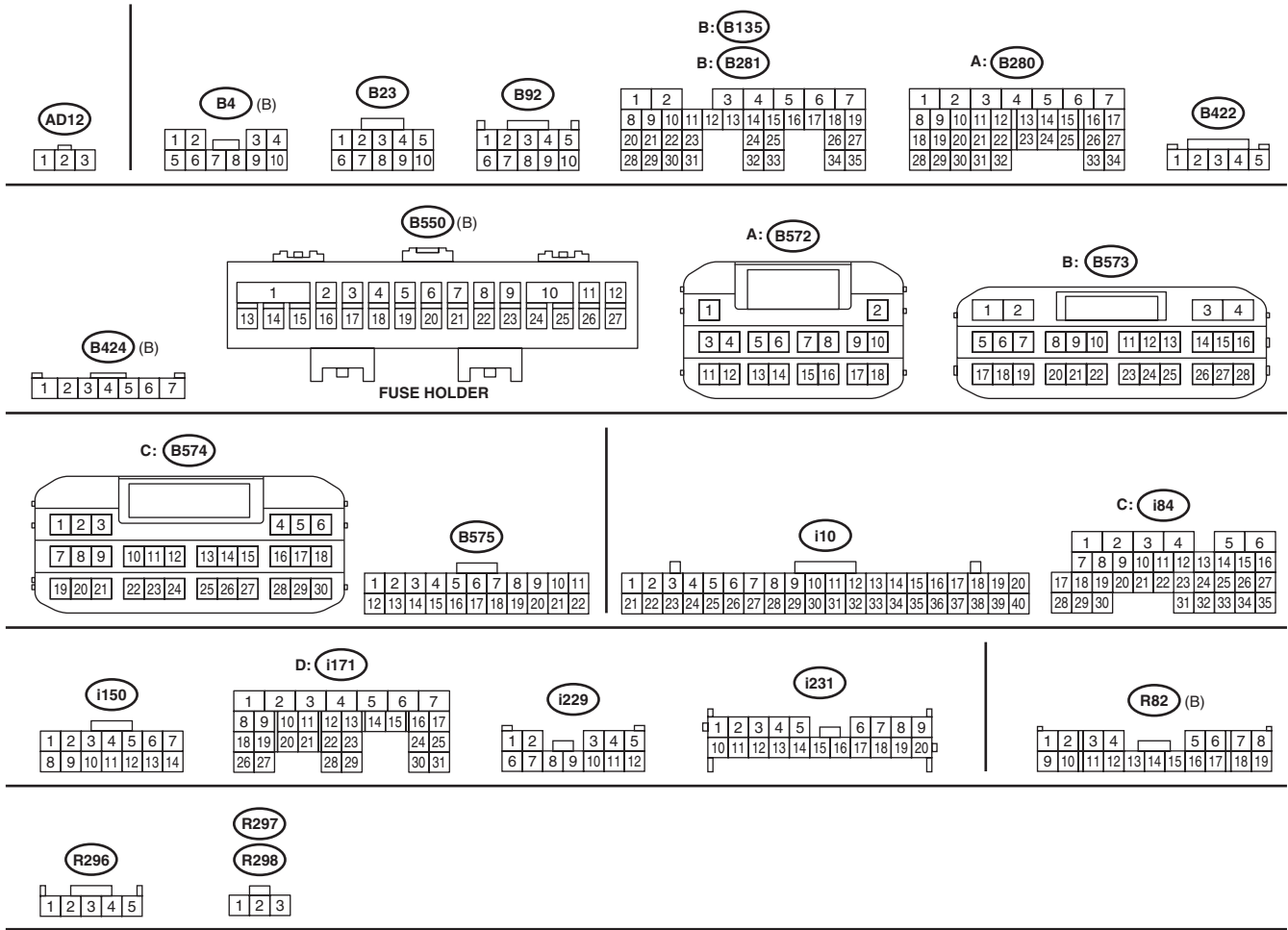

WI-44469